

**PLEASE READ AND SAVE
ALL INSTRUCTIONS!**

AIR-O-SWISS 
ADVANCED AIR TREATMENT SYSTEMS

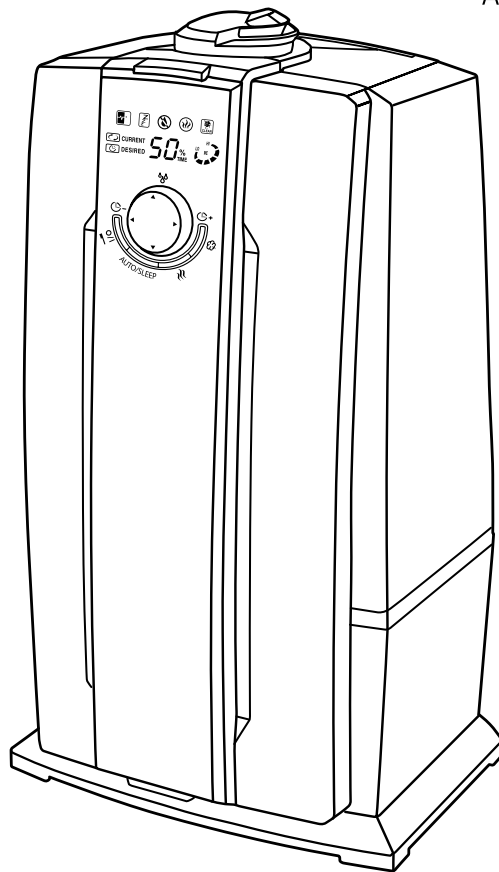

AOS 7142



PLEASE READ AND SAVE ALL THESE INSTRUCTIONS!

Important safety instructions

- Prior to using the appliance, read through the instructions for complete use and retain in a safe place for later reference.
- **WARNING** – Only use the Ultrasonic indoors and within the specified technical data. Improper use can be hazardous for the health and lead to critical injury.
- Connect the unit only to alternating current with voltage according to the rating label.
- Children cannot recognize the hazards associated with the usage of electrical appliances. For this reason, always supervise children when they are near the humidifier (image 1).
- Never use the appliance if there is any damage to the appliance or cable (2), after malfunction, after the appliance has been dropped (3) or damaged in any other way.
- Repairs of electrical appliances are only to be made by qualified service engineers (4). Improper repair work can cause considerable danger to the user.
- Place the humidifier on a dry, level surface (5).
- **Do not place the appliance directly on the floor** or next to a heating vent (6).
- If the mist comes in contact with the floor prior to evaporating, the floor surface can become damaged. We do not accept any liability for damages in the case of incorrect placement of the unit.
- The unit should be placed in an elevated position (7), e.g. on a table, chest of drawers, etc.
- Place appliance where it is not easily knocked over (8).
- Always unplug when not in use.
- Only operate the humidifier when it is completely assembled.
- **ALWAYS** unplug before removing/filling/emptying the water tank, before cleaning/maintaining, assembling/dismantling of individual parts and before moving the appliance.
- Do not touch the water in the base during operation because of high frequency vibrations in the water.
- Do not run power cords under carpets, and do not cover with throw rugs. Arrange cord so that it will not be tripped over.
- Never pull the plug from the outlet by the cable or with wet hands.
- Do not use the appliance where combustible gases or vapors are present.
- Do not expose the appliance to rain, or use near water, in a bathroom, laundry area or other damp location.
- This unit must be used in its upright position.
- Do not allow foreign objects to enter ventilation or exhaust opening as this may cause electric shock or damage to the appliance. Do not block air outlets or intakes.
- Do not pour water into the mist outlet of the appliance.
- This appliance has a polarized plug (one blade is wider than the other). To reduce risk of shock, this plug is intended to fit in a polarized outlet only one way. If the plug does not fit fully in the outlet, reverse the plug. If it still does not fit, contact a qualified electrician. **DO NOT** attempt to defeat this safety feature.
- A loose fit between the plug (receptacle) and the AC outlet may cause overheating and a distortion of the plug. Contact a qualified electrician to replace loose or worn receptacles.
- Do not sit, stand or place any heavy objects on the appliance.
- Do not submerge the main body in water or other liquids.
- Disconnect power supply before servicing.
- Persons who are not familiar with the instructions for use, as well as children and persons under the influence of medication, alcohol, or drugs are not permitted to operate the appliance, or are only permitted to operate it under supervision.
- The use of water additives, such as ethereal/essential oils, fragrances, eucalyptus, water conditioners etc., damages the tank material and as a consequence the whole unit. Any use of such additives will void the manufacturer's warranty.
- Remark: Neither humans nor animals can hear the high frequency vibrations.

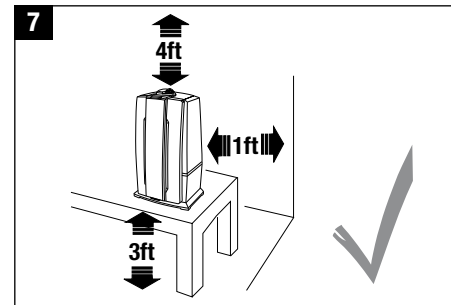
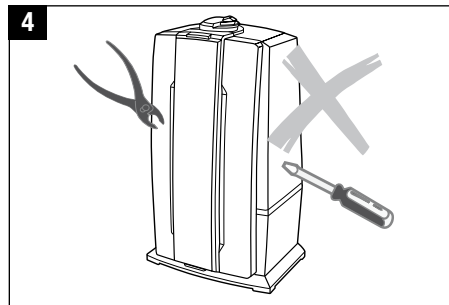

en

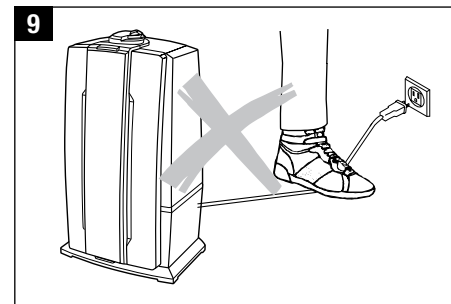
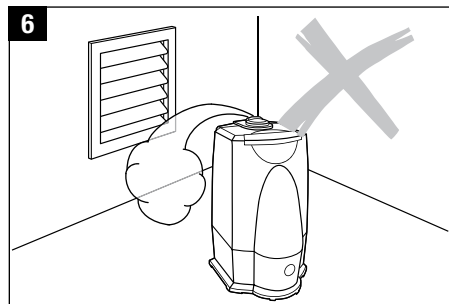
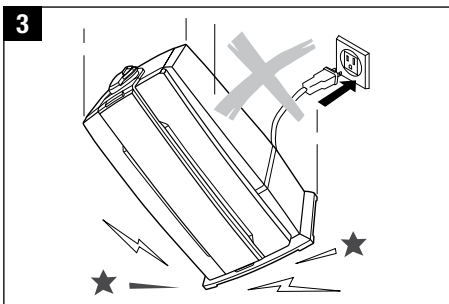
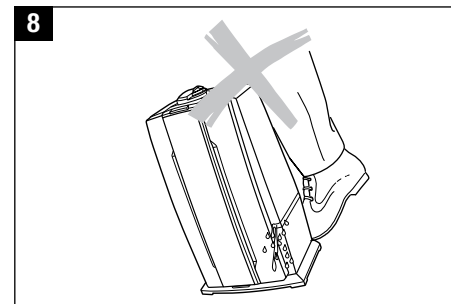
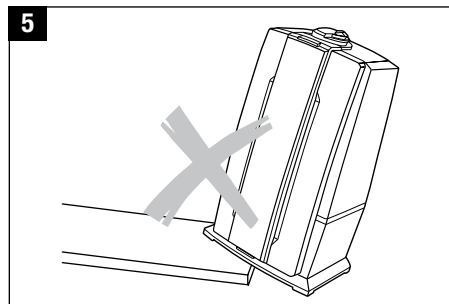
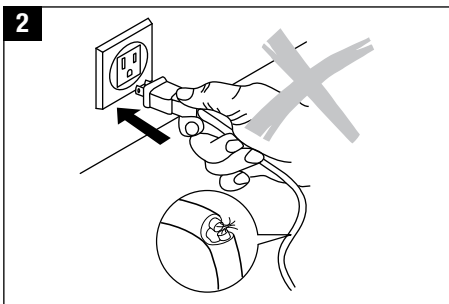

Foreword

Congratulations on choosing the Ultrasonic AIR-O-SWISS 7142! Did you know that dry room air:

- Causes the membranes in your respiratory system to dry out, and also causes chapped lips and stinging eyes?
- Encourages infections and illnesses of respiratory system?
- Causes weariness, tiredness and poor concentration?
- Stresses household pets and house plants?
- Encourages the formation of dust and the electrostatic charging of textiles made of synthetic fibers, carpets and plastic flooring?
- Damages furnishings made of wood and parquet?
- Detunes musical instruments?

General information

A comfortable atmosphere indoors is reached with a relative humidity level between 40 and 60%. Your humidifier automatically controls the humidity level according to desired setting. If the air is too dry, the humidifier will automatically switch on. As soon as the desired humidity level is reached, it will switch off.

Unpacking

- Carefully remove the humidifier from the box. Place your hands underneath the product to pull it out of the box (10).
- Warning: Do not take the unit out of the box by pulling up on the tank handle - base may fall and will be damaged (11).
- Warning: The mist outlet is packed in a red bag inside the box insert. Make sure that you remove the mist outlet from the packaging (12).
- Remove the plastic bag from the humidifier.
- Observe the information given on the rating plate about the voltage.
- There is a protective label on the control panel in order to protect the surface. Please remove it as shown before the first use (13).
- Use the original packaging for storing the appliance if you do not use the humidifier all year round.

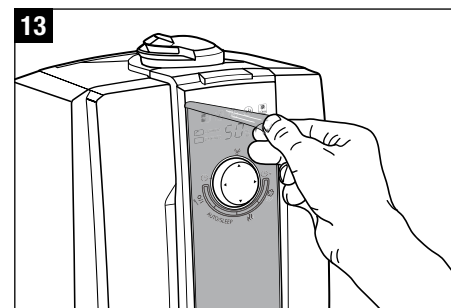
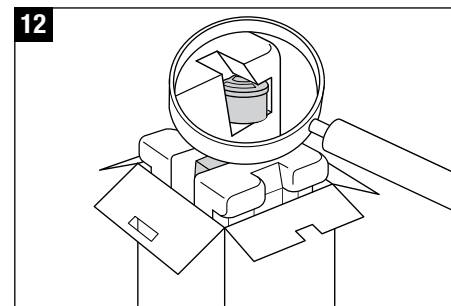
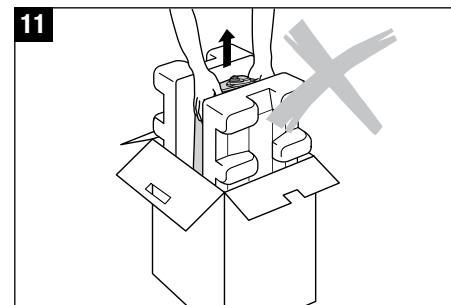
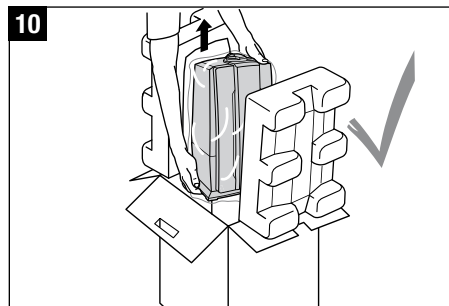

Description of the appliance

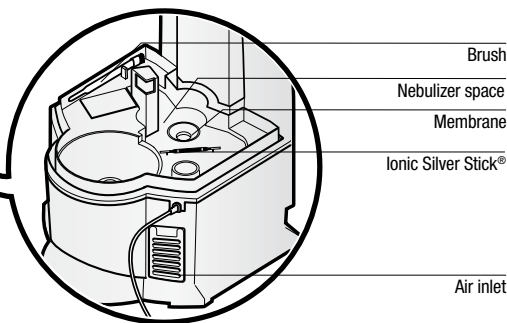
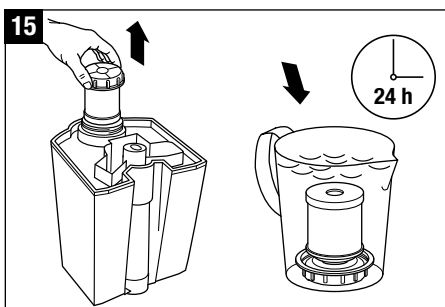
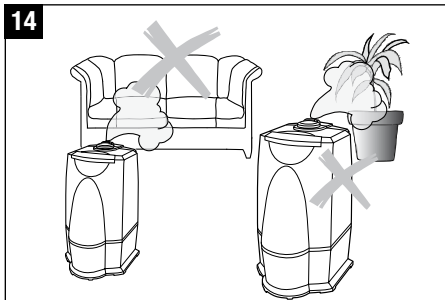
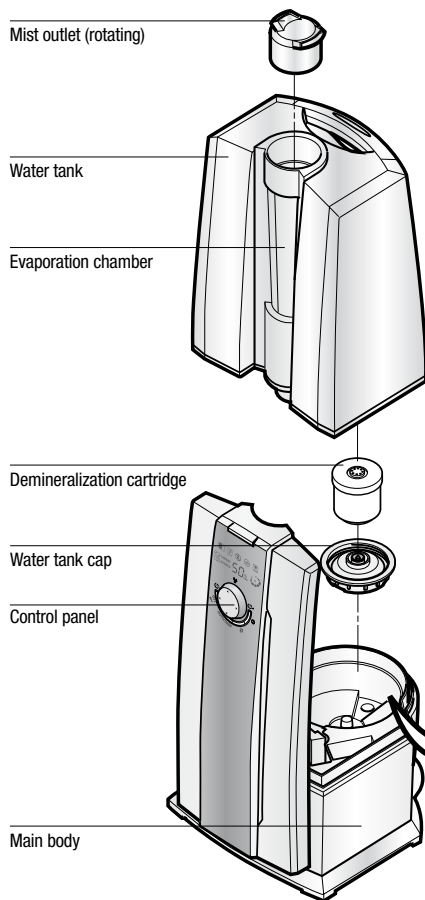

Setting up

Finding the ideal location for your unit:

- Do not place the humidifier directly next to a heating vent or on a floor with floor heating. The moisture of the mist can damage the floor surface (6) (see Safety Instructions).
- The unit should be placed in an elevated position (7), e.g. on a table, chest, etc. at least 3 ft off the floor.
- The mist outlet must not be pointed directly at plants, furniture, or other objects (14). Keep distance of at least 20 inches (50cm).
- Soak the demineralization cartridge in a water bath 24 hours before using it (15). The resin has to absorb water to reach high performance. If it is soaked in the tank, make sure to exchange the water and empty the water from the base before using the humidifier.
- On average the demineralization cartridge should be replaced every 2 – 3 months depending on your water hardness. Some areas may need to replace the cartridge sooner, some may last longer. The cartridge must be exchanged at the latest after 6 months or the unit does not reach its full performance anymore. See «Replacement of the demineralization cartridge».
- Read the instructions under «Filling the Tank» for adding water in the humidifier (16 and 17).
- Place the water tank onto the base.
- Insert the plug into the socket and switch on the appliance using the on/off dial (20).
- About 10 to 15 minutes after it is switched on the device will reach its full output level.
- Make sure that the cable is not pinched anywhere (9). Do not operate the humidifier if the cable is damaged (2).

Filling the tank



Always unplug the unit before removing the water tank. Do not touch the water in the base during operation!

Do not operate the humidifier when the water tank is empty! When the water reaches the minimum level, the unit switches off the nebulizer function automatically. The red light comes on indicating tank is empty.

- Remove the water tank from the base and unscrew the water tank cap (16). Caution: the mist outlet is loose!
- Make sure that no foreign objects are in the water tank.
- Fill the tank with clean, cold water from the tap (17). Close the cap of the water tank securely, place the water tank onto the base (18). The water is now running from the tank into the base.
- Do not pour water into the mist outlet of the appliance (19).
- Insert the plug into the socket and switch on the appliance using the on/off dial (20). The red empty indicator light may stay illuminated for some seconds until the base is filled with water. Then the green light comes on.

Use of additives

Water additives (ethereal/essential oils, fragrances, eucalyptus, water conditioners, etc.) must not be used! Even a small amount can cause cracks in the material. The material isn't made for the use of such additives. One drop is enough to damage the tank and as a consequence the unit. Any use of such additives will void the manufacturer's warranty.

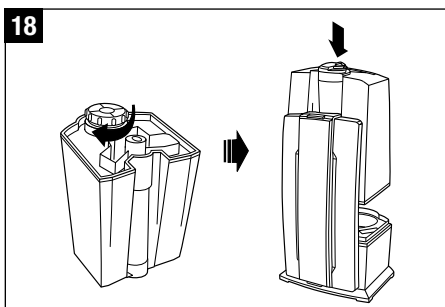
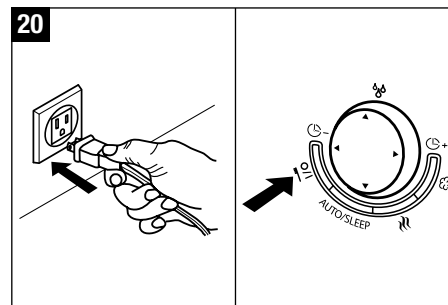
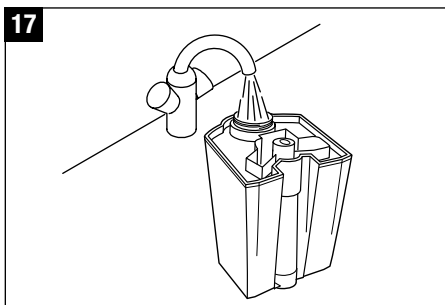
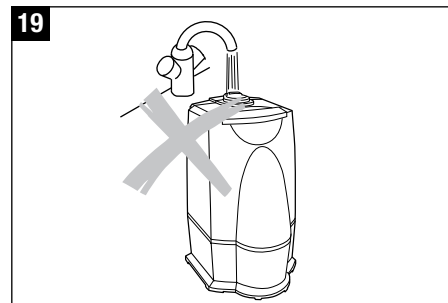
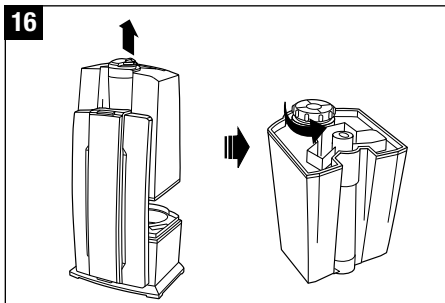

Operation 7142

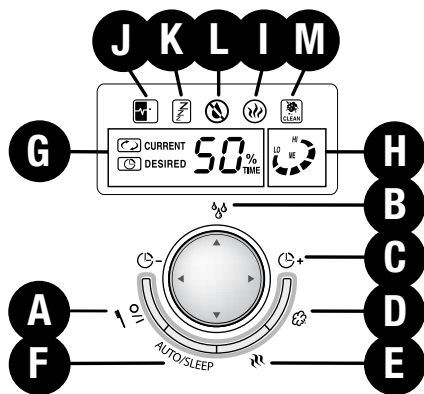

A) On/Off dial

You can switch the unit on or off by pressing button A. This button is also used to reset the cleaning indicator light (by holding down).

B) Hygrostat (setting the humidity level)

By pressing multi-functional button B (vertical) you can set the desired humidity level in %. A relative humidity of between 40 and 60% is recommended. The accuracy of measurement is +/- 5%. The unit will switch off when the moisture level exceeds the desired setting. During selection the target value is displayed. The display will automatically show the current value after a few seconds.

C) Timer

Using multi-functional button C (horizontal), the operation time can be set adjustable between 1 and 8 hours. **Symbol G** shows the operating period that has been set (1h/2h/3h/4h/5h/6h/7h/8h). The display will automatically show the current value after a few seconds.

D) Mist output (regulating mist output)

By repeatedly pressing button D you can control the mist output. The LO/ME/HI display (**symbol H**) shows which of the three levels (low/medium/high) you have selected.

E) Operation with pre-heating (warm mist)

Button E is used for switching the pre-heating on and off (**symbol I** lights up). As a result, the water is pre-heated to a temperature of 176 °F (80 °C) before entering the nebulizer space. It takes approx. 10 to 15 minutes for the water in the base to warm up. The mist now leaves the humidifier at a pleasant temperature of 104 °F (40 °C). The advantage of this is that the room temperature does not drop and, in addition, it significantly improves the water quality maintenance.

F) Automatic mode and Sleep mode

The automatic and sleep modes can be activated by pressing button F. By pressing the button once, the automatic function is switched on (**symbol J** appears on the display), maintaining the optimum humidity subject to the temperature. Control takes place by means of output quantity and pre-set target value. If the sleep function is switched on (the **symbol K** appears on the display), the target humidity is 60%; the operation time is automatically set at 6 hours; the heating is switched on. In addition, the output quantity is also controlled subject to the difference between the target value and the actual value.

The Timer cannot be changed in either mode. If other buttons are pressed, the unit will no longer be in auto or sleep mode.

L) Empty indicator

The water level is easy to see, thanks to the transparent water tank. The appliance also alerts you when the water tank is empty. The empty indicator is illuminated (symbol L). Please read the chapter «Filling the tank» for more information. The Symbol L may stay illuminated for some seconds with a refilled tank until the base is filled with water.

M) Cleaning indicator

If symbol M and «CLEAN» appear on the display, the appliance should be cleaned as recommended by the manufacturer. This symbol comes on automatically every 2 weeks, depending on the level of use. **The display can be reset by holding down button A until the light disappears.**

Cleaning/Maintenance



Always unplug the unit before removing the water tank. Do not touch the water in the base during operation!

Caution – risk of electric shock and damage of the product!

- Switch off the appliance and unplug it from the socket before cleaning it (21).
- Clean the water tank and the base regularly. Use water only, no detergents (22).
- Use AIR-O-SWISS EZCal custom cleaning and descaling agent only to remove deposits from the membrane regularly (23 and 24). There is a sample of EZCal included in the packaging of your humidifier. Instructions for using are on the packet. Only use 1 packet for 32 oz of water. Do not change the ratio. Do NOT run the unit when using EZCal. This can cause damage to the product and voids the warranty. Thoroughly rinse the base with potable water after using EZCal and make sure no EZCal residues remain in the base.

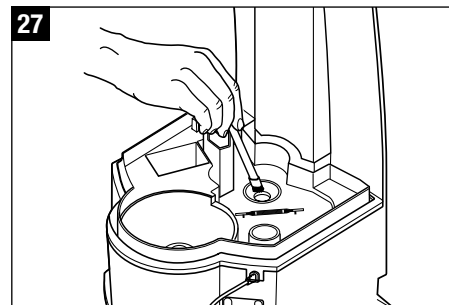
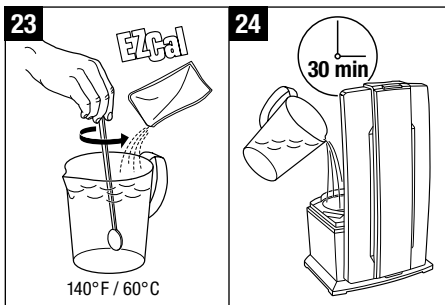
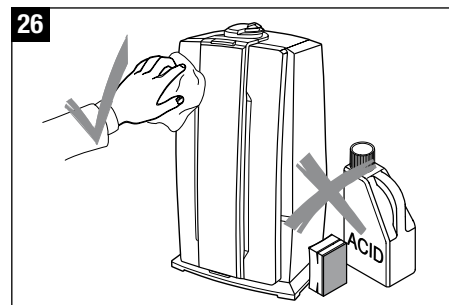
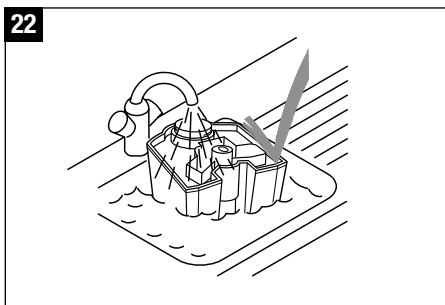
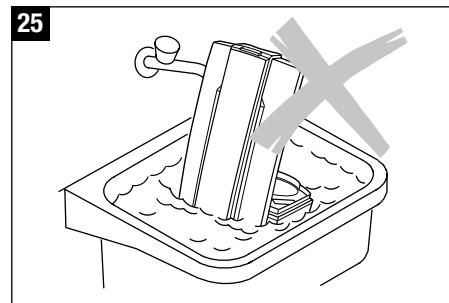
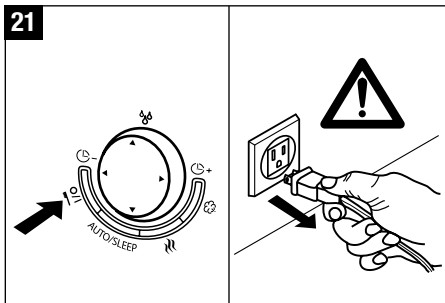



EZCal from AIR-O-SWISS is the only recommended cleaning and descaling solution. Do NOT use any other cleaning solutions since it can damage the product. Any use of cleaning solutions apart from EZCal will void the warranty.

- Make sure main body is never submerged in water (25)!
- The cleaning indicator still appears on the display after cleaning. To reset it hold down the ON/OFF button until the clean light stops flashing.
- Clean the inner parts with a soft cloth. Do not use any solvents or aggressive cleaning agents to clean the appliance (26).
- Only use the brush to clean the membrane. This should be done once a week. Only use the soft-bristle portion of the brush (27).
- Change the water in the tank at least once a week if water is standing for more than a week.

Water quality maintenance

The Ionic Silver Stick® (28) keeps the water free of microbial growth. The anti-microbial action of silver is used. The Ionic Silver Stick (ISS) releases silver ions in the water over a long period of time (approx. one year). It's self-regulating and maintenance-free. Look at picture 28 for the position of the ISS in the base part of the unit. Do not touch the water in the base during operation! Switch off the unit first. Contact your local retailer or check our website www.airoswiss.net for reorder information.

The Ionic Silver Stick® comes with a metallic clip which can be removed for the placement in this product type.

Lifecycle Indicator

Your appliance comes with a lifecycle indicator for changing the Ionic Silver Stick®. To remind yourself of when you put the ISS into operation, please cross the current month on the stamp and write the current year on the line provided (29).

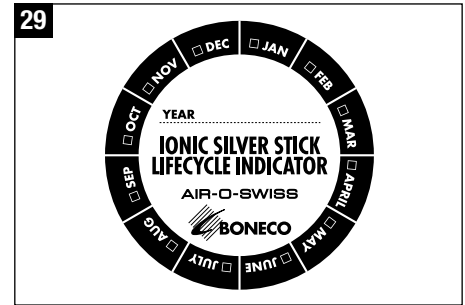
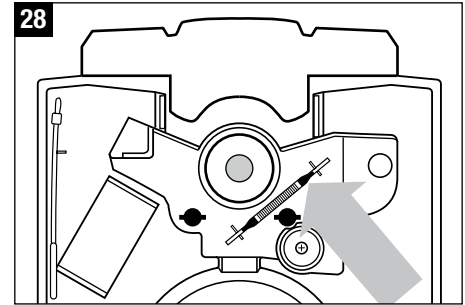

Replacement of the demineralization cartridge



Always unplug the unit before removing the water tank. Do not touch the water in the base during operation!

The water tank is equipped with a demineralization cartridge. This cartridge has to be replaced every 2 – 3 months. If the water is very hard, it may be necessary to replace the cartridge earlier. White dust around the device is a sure sign that the cartridge needs replacing. Please note white dust is not harmful. If white residue still forms around the device after a new cartridge has been inserted, please make sure that the water you are using is untreated. If the water flows through a decalcification system – such as an ion exchanger – (sodium is added to remove calcium) in the building before it is used in the humidifier, salt can precipitate as white dust around the device. The demineralization cartridge and/or the granules must be exchanged at the latest after 6 months or the unit does not reach its full performance anymore.

Option A: replace the resin

- Remove the water tank from the base and unscrew the water tank cap (30). Caution: the mist outlet is loose!
- The demineralization cartridge is attached to the tank cap. Unscrew the cartridge from the cap by turning it counter-clockwise (31). Important: do NOT dispose of the water tank cap!
- Open the cartridge (32).
- Throw the content into the waste (Attention! Disposed resin can make the floor slippery!) (33).
- Place the enclosed pink styrofoam piece in the center of the cartridge. Do not push it to the bottom as it will be difficult to remove afterwards (34).
- Pour the contents of one refill resin bag into the plastic cup that is included with the refill resin packaging (35).
- Place the empty cartridge with the plug in the center onto the plastic cup (36).
- Turn the plastic cup and cartridge over and shake until all resin is in the cartridge (37).

- Remove the plastic cup and the pink styrofoam piece from the cartridge (38) and retain for future use (the refill resin consists of 3 refill bags) (39).
- Close the cartridge (40).
- Soak the demineralization cartridge in a water bath 24 hours before using it (43). The resin has to absorb water to reach high performance. If it is soaked in the tank, make sure to exchange the water and empty the water from the base before using the humidifier.
- Screw the cartridge on the water tank cap (44).
- Screw the cartridge on the bottom side of the water tank, put the tank on the main body (45).



Placing granules in the center of the cartridge allows them to escape in the unit or to clog the unit. The unit will no longer operate properly and the granules need to be cleaned out thoroughly.

Option B: replace the whole cartridge

- Remove the water tank from the base and unscrew the water tank cap (30). Caution: the mist outlet is loose!
- The demineralization cartridge is attached to the tank cap. Unscrew the cartridge from the cap by turning it counter-clockwise (31). Important: do NOT dispose of the water tank cap!
- Throw the whole cartridge into the waste (41).
- Unpack the new cartridge (42).
- Soak the demineralization cartridge in a water bath 24 hours before using it (43). The resin has to absorb water to reach high performance. If it is soaked in the tank, make sure to exchange the water and empty the water from the base before using the humidifier.
- Screw the cartridge on the water tank cap (44). Close tank cap well and place the tank on the main body (45).

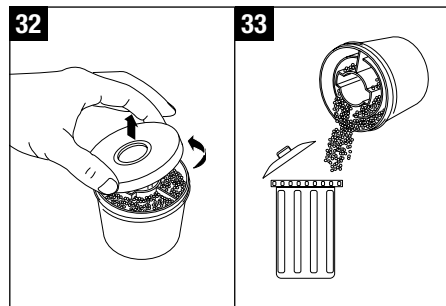
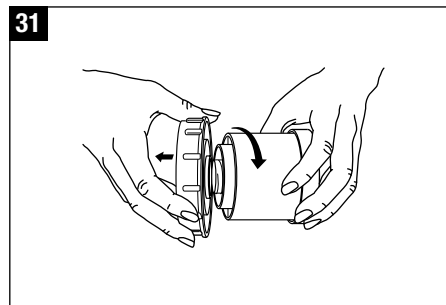
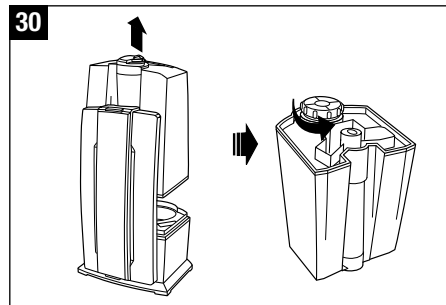

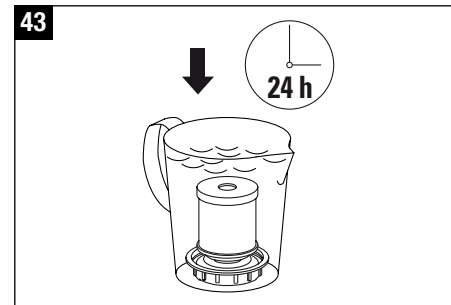
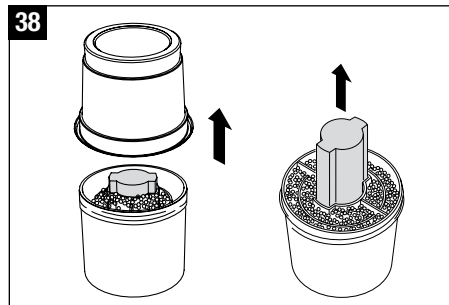
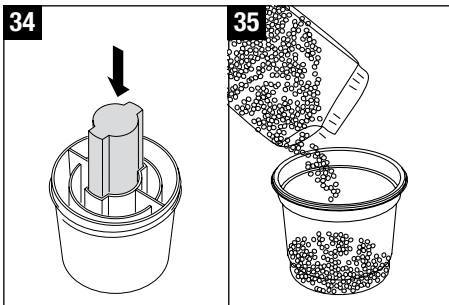

en

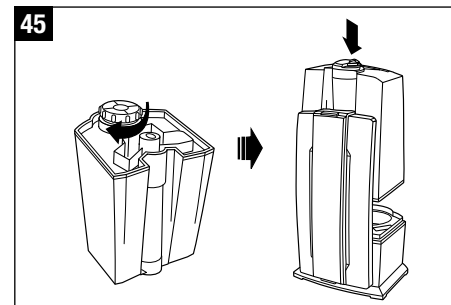
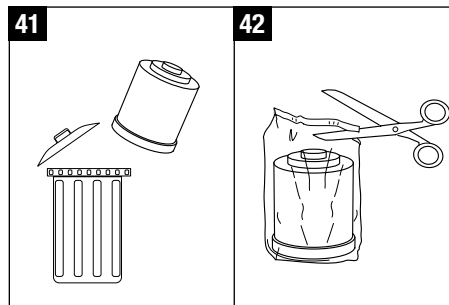
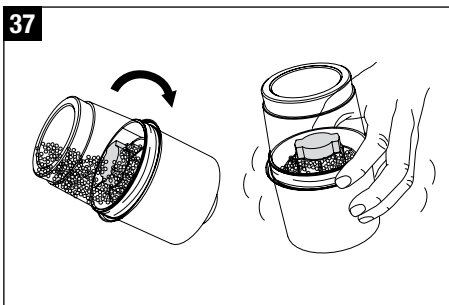
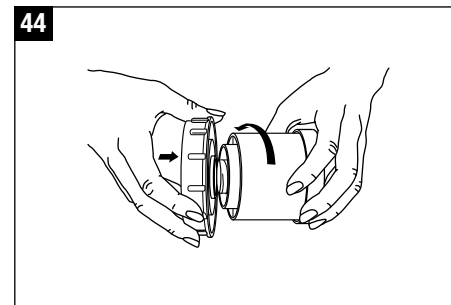
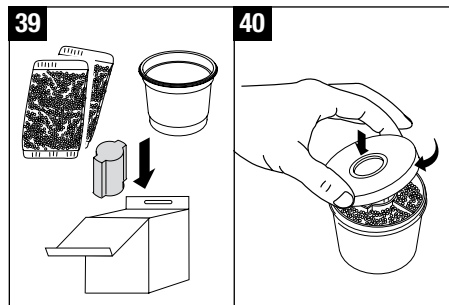
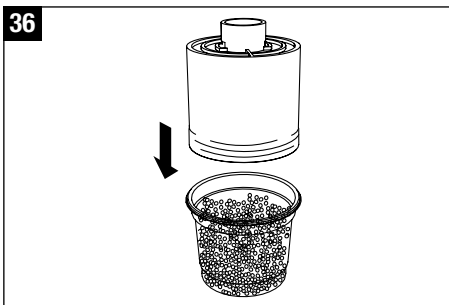

Storing the appliance for extended periods

Clean the appliance as described earlier and allow to dry thoroughly. Preferably store the appliance in its original box, in a dry place away from high temperatures.

Legal notice

The humidifier is cUL-listed.

Subject to technical change. The instructions for use are protected by copyright © PLASTON AG.

Accessories

Contact your local retailer or check our website www.airoswiss.net for re-order information.

Customer Service

Customer Service (USA) 1-800-336-0326
www.airoswiss.net

Technical data

Electrical voltage	120 V / 60 Hz
Power consumption up to	45 W / (140W*)
Humidity output up to	3.5 gallons / 24 h*
Suitable for rooms up to	860 sq ft / 80 m ²
Dimensions (LxWxH)	9.8 x 11.0 x 17.3 in 25 x 28 x 44 cm
Weight (empty)	8.8 lbs / 4 kg
Accessories	Demineralization cartridge Ionic Silver Stick®

* when used with pre-heating to 176 °F (80 °C)

Trouble shooting

Problem	Possible cause	What to do
Unit does not operate	Power cable not plugged in	Plug in power cable
	No water in the tank (Empty-light red)	Fill tank with water and wait 10 min.
No mist output	Unit needs cleaning	Descalc the water base using EZCal
	DMC exhausted	Replace cartridge or granules
	DMC overfilled with granules	Take out 2 tablespoons of granules and throw them away
Weak mist output	Water temperature too low	Set mist output to maximum, after 15 min. the humidifier will work properly again
	Mineral deposits on membrane	Clean membrane using EZCal and brush
Unit running intermittently		
White dust around the humidifier	Demineralization cartridge exhausted	Replace demineralization cartridge or resin

General Humidifier Questions

Q. Why isn't there enough moisture in my room?

A. How often do you run the unit? If the unit is only run at night, then during the day the moisture level will drop if moisture is not constantly added to the air.

Q. Do you leave your door open or closed when the unit is running?

- A. a) By leaving the door open, this allows moisture to leave the room and go into other areas of the house. If you would like the moisture to stay within one specific room you should consider closing the door while the unit is running.
- A. b) Wood, leather, carpet, curtains, and other types of fabric soak up a lot of moisture, thus not leaving enough moisture for the air. If the window is left open, then this allows moisture to escape the room. Another factor is a lot of times the unit is placed next to a heating device. The idea is that the air blowing into the room will quickly place moisture around the room. Unfortunately, this concept does not work because the hot air coming out of a vent will soak up most of the moisture, and none of the air within the room will receive any.

Q. How much moisture do I need in my room?

A. Suggested humidity levels are between 40 – 60%.

Q. What are the effects of too little or too much humidity?

A. Dry air can cause dry skin, static electricity, out of tune musical instruments, increased levels of dust (dry air causes dust to rise), damage to wooden objects (dry out and eventually cracks appear), discomfort, sickness, and dries out nasal membranes. Over-humidifying the air can cause mold and wallpaper to peel.

Q. Why do I need a humidifier when I can just open my window?

A. The moisture level within the outside air is not high enough to humidify a room. The colder the air the less moisture it is capable to hold, and the more the air is heated up the percentage of relative humidity is lower. Relative humidity means the amount of water vapor in the air, compared to the amount the air could hold if it was totally saturated. The difference is higher between outside and inside temperatures; more humidification is needed because of the dry air in the room.

Q. Where should I place my humidifier?

A. The unit should be free-standing and not close to a wall, window, door, or thermal bridge so that air may circulate around the unit.

Ultrasonic Frequent Questions

Q. Why does it say open/close on the demineralization cartridge cap?

A. Those directions are there in case you decide to use the refill option to replace the granules; the purpose is for how to open and close the cap. If you did open the cap before placing it in the water tank, you will most likely notice that there are granules in the water tank and the base of the unit. Immediately turn off the unit, and empty the water out of the base and the water tank. Begin removing all granules from base and water tank. Use brush to clean around membrane. Caution: Do not dispose of granules in sink! Used granules must go in waste!

Q. I just replaced my cartridge, and the contents and water in the base has turned a blue-green color.

A. This sometimes occurs when the cartridge, or even the granules, are replaced. This does not occur with all replacement cartridges or granules, and is a reaction of water content and the Ultrasonic vibrations. This is not an indicator to replace the cartridge.

Q. There is no fill-line on the water tank, how far may I fill it up?

A. There is no fill line on the water tank, and it may be filled all the way to the top.

Q. What is the purpose of the demineralization cartridge (DMC)?

A. The DMC removes minerals from the water to prevent white dust. The contents of the cartridge need to be soaked for 24 hrs prior to first using the unit so that they may fully expand and remove minerals from the water. The contents of the DMC have a life of 2 – 3 months. The cartridge may need to be replaced more often depending on water hardness and how often the unit is used. An indication of when the DMC needs to be changed can be white dust or reduced amount of mist output.

Q. Is it ok to use distilled water with the unit?

A. For best results with your ultrasonic humidifier use distilled or reverse-osmosis water and remove the demineralization cartridge.

Q. I just replaced the contents of the cartridge and now have granules everywhere.

A. First, make sure there are no granules in the middle of the cartridge. Placing granules in the middle of the DMC allows them to escape in the unit. Immediately turn off the unit, and empty the water out of the base and the water tank. Begin removing all granules from base and water tank. Use brush to clean around membrane. Caution: Do not dispose of granules in sink! Used granules must go in waste!

Q. The directions tell me not to place the unit directly on the floor, why do I have to elevate the unit?

A. The idea with this unit is to allow one to force humidity into the air. Because of this, the carpeting or wood floor surrounding the unit may become damp. If the unit is

placed at least 3 feet off the floor, the mist will have the opportunity to evaporate before hitting the floor.

Q. Water does not go into the tank.

A. In order to fill the tank, it must be turned upside down. The cartridge is placed on the water tank cap. Do not pour water in the tube which is the mist outlet.

Q. White dust is emitted from the unit

A. White dust particles are minerals that are broken up in tiny pieces by the ultrasonic process.

Solve the problem:

- Soak the demineralization cartridge in a bowl of water for a minimum of 24 hours. If the cartridge is soaked in the water tank, the water in the tank and the base needs to be replaced before using the unit.
- Exchange the demineralization cartridge after 1-2 months when you use very hard water (for softer water after 2-3 months). No matter how hard your water is, exchange the cartridge at the very latest after 6 months.
- Don't use water from a pre-installed water softener, or sodium instead of calcium will be emitted from the unit. Use distilled water instead and remove the demineralization cartridge.
- For very hard water areas use only distilled water and remove the demineralization cartridge.
- Use Reverse-Osmosis water (R-O water) instead of distilled water and remove the demineralization cartridge.

• Cleaning light is flashing (model 7135/7142/7144)

Switch off the unit and unplug it. Empty the water in the base. Rinse the base with hot/clean water. Do not submerge the base! Visually inspect the base for dirt or mineral build up. If soft water is used decalcifying the unit every 4 weeks with EZ Cal is suggested. If hard water is used the unit should be decalcified every 2 weeks. Do not forget to reset the clean light after resetting the unit.

Q. Reset cleaning light (model 7135/7142/7144)

A. The cleaning light does not automatically reset. Hold down the power button (button A in instruction manual) until the light stops flashing. The light automatically comes on approx. after 14 days of plugging in the unit.

Q. The hygrometer on unit reads a different humidity level than external hygrometer.

A. Not all hygrometers are calibrated the same, and most are off by +/- 5%. Plus the humidity level is not the same in the whole room. The air circulation is different in every corner of the room. The unit should not be placed near a heating vent or a radiator as the heat will absorb all of the moisture.

Q. Humidity level is not changing or does not reach the desired humidity level.

A. If the water tank needs refilling more than once per day, the unit is working properly and the climatic condition in the room has an influence on the humidity.

Reasons for low humidity level:

- air circulation is very high (air is fully exchanged several times per day – the humidifier needs to start its work from scratch)
- insulation of home (see air circulation)
- open space with high ceilings (not only the footage of the room counts but also the height) – high-rise buildings require more humidification.
- open windows – works similar to air circulation (if it is very cold outside don't open the window more than 2 times per day for 3 minutes)
- big difference between outside temperature and inside temperature – the colder the air the less moisture it is capable to hold and the more the air is heated up the lower is the percentage of relative humidity (=the amount of water vapor in the air, compared to the amount the air could hold if it was totally saturated)
- position of the unit - if it is placed close to a door, window or air vent. This increases the air circulation.

Q. Tank is leaking

A. Check if there are any hairline cracks. Dropped units or water tanks that are cracked will not be covered under the warranty. Please contact the retailer the unit was purchased from in case your unit arrives damaged.

Q. Placing the face in the mist

A. It is not recommended that anybody places their face in the mist. It is an electrical product and should not be played with.

Q. No mist / unit is not working / empty indicator keeps flashing

A. Fill up the water tank. Check if water is flowing through the demineralization cartridge (attached to the water tank cap). If the water tank is full but there is only little water in the base it indicates that the water is now flowing through the demineralization cartridge.

- Wait for 15 minutes to allow the mist to come out of the unit.
- If the unit is not working and the empty light is not flashing you might have set the desired humidity too low and the current humidity level in the room is higher. That is why the unit switches off automatically.
- If the empty indicator keeps flashing and the tank is full, the water is not flowing through the cartridge. Exchange the cartridge or the granules in the cartridge after 2-3 months, in areas with hard water exchange the cartridge after 1-2 months. However, the demineralization cartridge and/or the granules must be exchanged at the latest after 6 months or the unit does not reach its full performance anymore
- If the granules are new, see the following instructions:
- Make sure the cartridge and/or granules were soaked for 24 hours, dry granules take even longer for water to filter through the cartridge and into the base. Next, please remove 2 tablespoons of granules from the cartridge, and throw them away. When there are too many granules in the cartridge it does not allow water to flow from the tank to the base.

Q. Water tank cap is too tight to unscrew

A. This could be a cause of the air pressure within the water tank. Depress the spring on the bottom of the water tank cap to release air from the water tank. Continue to do this until you are able to unscrew the water tank cap.

Q. Unit is running intermittently.

A. How long has it been since the contents of the cartridge were replaced? If 2-3 months have passed, it is time to replace the contents of the cartridge. However the demineralization cartridge and or the granules must be exchanged at the latest after 6 months or the unit does not reach its full performance anymore.

- If the contents of the cartridge were just replaced there are probably too many granules in the cartridge. Remove 2 tablespoons of granules from the cartridge.

Accessories**Q. Do I need to keep any parts before I replace the demineralization cartridge?**

A. Yes, always keep the water tank cap (this is the piece that attaches the demineralization cartridge to the water tank).

Q. Ionic Silver Stick® (water treatment) replacement reminder

A. In each Ionic Silver Stick® (ISS) box and on all the new products there is an ISS lifecycle indicator. Check the box of the month when starting to use the ISS and write the year on the line indicated. Exchange it after 12 months.

Q. What is EZ Cal?

A. There is a sample packet of EZCal included in the packaging of your humidifier. EZCal is used for cleaning and descaling any of the AIR-O-SWISS products, and cleans mineral build-up. EZCal is the only recommen-

ded cleaning and descaling solution. Do NOT use any other cleaning solutions since it can damage the product. Any use of cleaning solutions apart from EZCal will void the warranty. Instructions for using are on the packet. Only use 1 packet for 32oz of water. Do not change the ratio. It can also be used for any other humidifier brand. Do NOT run the unit when using EZCal. This can cause damage to the product and voids the warranty. Thoroughly rinse the base with potable water and make sure no EZCal residues remain in the base! EZCal is available at selected retail stores.

Please check our website www.airoswiss.net
for further information.



AIR-O-SWISS is a brand name
of PLASTON AG, Switzerland.