

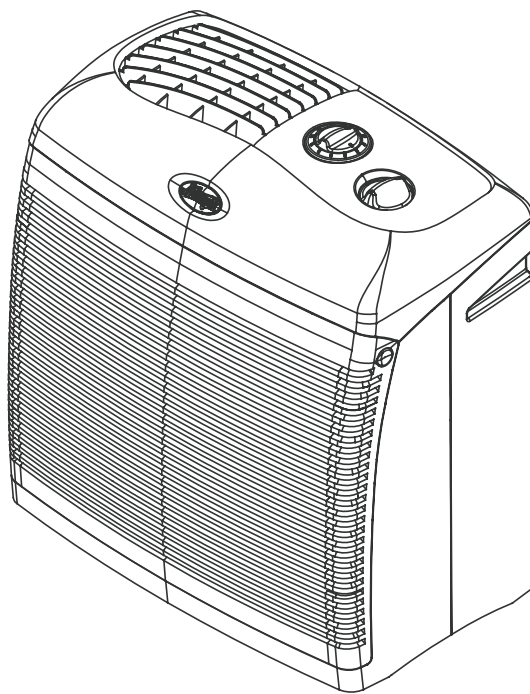

QuietFlo®

HEPA AIR PURIFIER SYSTEM



Model 30085

Replacement Filter Information		
<u>Model</u>	<u>Pre-Filter</u>	<u>HEPA Filter</u>
30085	30901	30936

IMPORTANT SAFETY INSTRUCTIONS
READ ALL INSTRUCTIONS BEFORE USING THIS AIR
PURIFIER AND SAVE THESE IMPORTANT
INSTRUCTIONS

1. **This Air Purifier is designed for use on a flat, level surface and may not work properly on an uneven surface. ALWAYS place this Air Purifier on a firm, level surface. ALWAYS place the Air Purifier at least six (6) inches away from walls and heat sources such as stoves, radiators, or heaters.**
2. **Place the Air Purifier in an area that is out of the reach of children.**
3. **Before using the Air Purifier, extend the cord and inspect for any signs of damage. DO NOT use the product if the cord has been damaged.**
4. **This product has a polarized plug (one blade is wider than the other) as a safety feature. This plug will fit into a polarized outlet only one way. If the plug does not fit fully into the outlet, reverse the plug. If it still does not fit, contact a qualified electrician. DO NOT attempt to defeat or override this safety feature.**
5. **ALWAYS UNPLUG the Air Purifier when it is not in operation, while the filter is being changed, and while it is being cleaned.**
6. **DO NOT tilt or move the Air Purifier while it is in operation. Shut off and unplug before moving.**
7. **DO NOT immerse the Air Purifier in water as permanent damage will occur. Refer to and follow the CLEANING AND FILTER REPLACEMENT instructions.**

Introduction

Thank you for purchasing the Quietflo™ Air Purification System from Hunter Fan Company. You have purchased our latest development in portable Air Purification Systems. This system has been developed to improve the quality of the air you breathe.

Our Quietflo™ Air Purification System out performs other air purification systems by quickly and effectively removing dust, smoke, and pollen particles as small as .3 microns in size. Room air is pulled in through the front grill and cleaned across the Quietflo™ filter. Clean air is then released out the top grill in order to avoid stirring up settled particles.

Using Your Air Purifier

1. Take the air purifier out of the box and remove the clear plastic protective bag. Place the unit on a firm level floor.
2. Before turning on the air purifier, you need to confirm that the filters are firmly in place and have not become loose during shipping. To check the filters, open the front grill by placing your fingers under the handle and pulling the front grill towards you. The front grill will rest open at about 45°. You can remove the front grill by placing your fingers under the handle and pulling the front grill towards you and then up.
3. Before turning the Air Purifier 'on', you need to open the front grill.
To release the front grill, press the buttons on the side until the front grill slides easily over the buttons.
4. The carbon pre-filter is mounted inside the front grill with hook tape. Confirm that it properly covers the grill vents. You may notice a few black particles coming off the pre-filter. Those particles are part of the odor-removing activated carbon and will be collected on the filter during use.
5. Place the front grill back onto the unit. First, line up the tabs on the bottom of the grill with the openings on the purifier base and then push the top of the grill forward until it is closed. **NOTE:** This unit will not operate unless the grill is in the correct position.
6. Plug the unit into a 120V electrical outlet.

Operating Your Air Purifier

On/Speed Control: Rotate the Speed Control knob to set the desired speed. A setting of zero (0) indicates that the unit is off, one (1) is low speed, two (2) is medium speed, and three (3) is high speed. The fan speed can be adjusted at any time.

Filter Change Calendar: The filter counter is designed to optimize the performance of the air purifier by reminding you when to change the Quietflo™ Filter and pre-filter. See Figure 1.

Quietflo Filter Calendar: The Quietflo™ Filter indicator is located at the top of the calendar ring. To set the Quietflo Filter counter, rotate the calendar ring to align the month that you installed the filter with the top indicator. Since the filter is designed for 6 months use, the two indicators will serve as reminders to change the filter every 6 months.

Pre-filter Calendar: The inner knob of the filter counter is the pre-filter counter. To use, align the knob with the month that you installed the pre-filter. The replace symbol on the inner knob points to the month in which you should install a new pre-filter. The pre-filter is designed for three months of usage.



Figure 1 - Calendar Knob

Cleaning And Filter Replacement

1. Clean the outside of the unit with a soft, damp cloth. The front grill can be removed and cleaned in soapy water. See Figures 2 and 3.

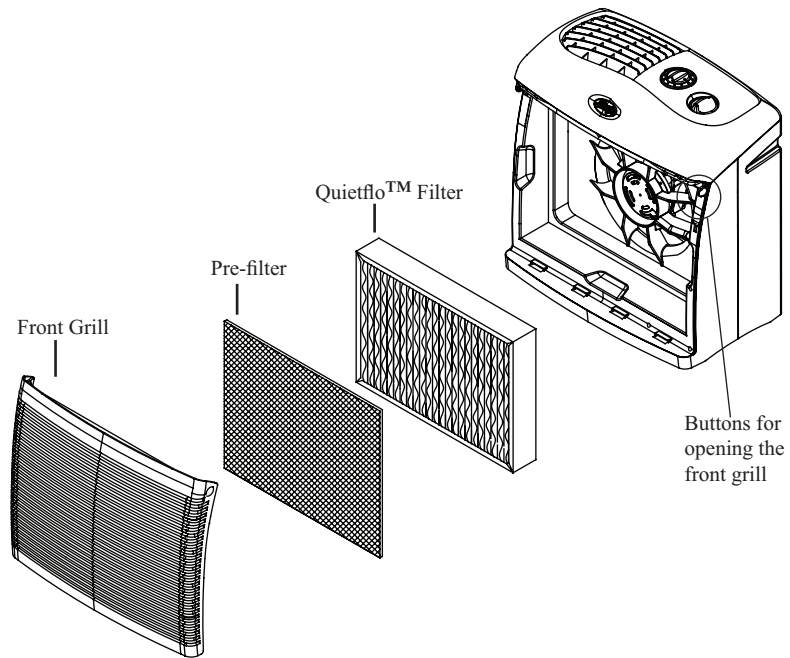

Figure 2

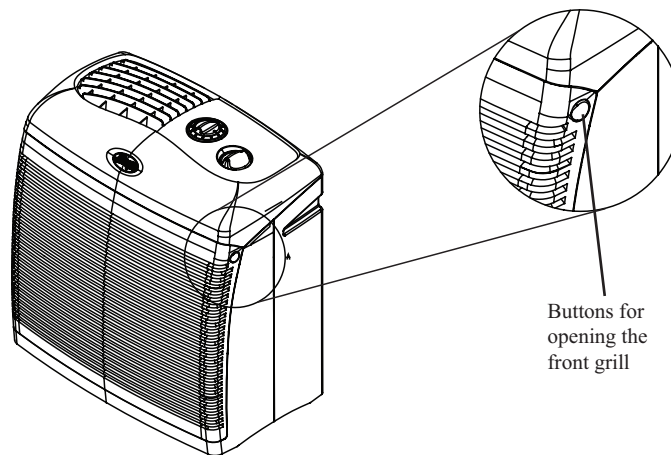
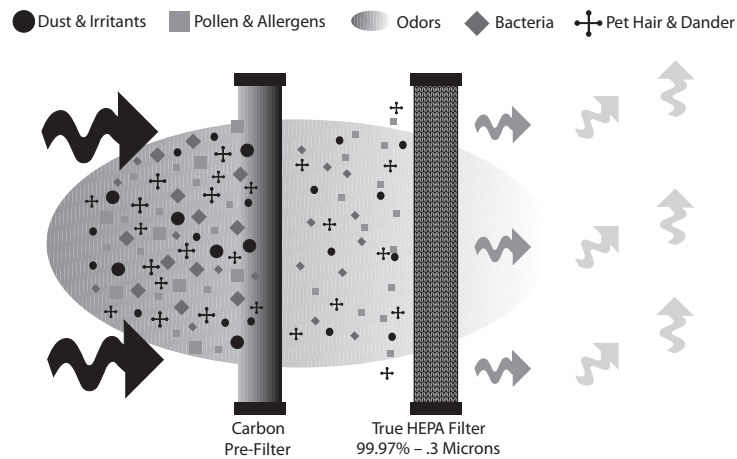

Figure 3

- At least every 90 days, open the front grill, remove the carbon pre-filter, and replace it. This is necessary to maintain proper odor-removing and overall filtration performance. If necessary, it can be changed more often. Mark the new filter installation sticker included with the new carbon pre-filter. Be sure to remove any plastic wrapping that may be on the new filter before you place it into the Air Purifier.



How The Quietflo™ System Works

The above is an illustration of how the Quietflo™ air purification system works. Dust and other irritants are pulled into the air purification system and cleaned through the Quietflo™ Filter. Clean, purified air is then released into the room.

Replacement Filters:

To obtain a replacement filter for your Air Purifier, call 1-800-4Hunter for your nearest retailer or Hunter Customer Service at 901-248-2222. Please be prepared to tell the operator the model number of your Air Purifier and the model number of the filter you need to replace.

Hunter Air Purifier Model No.: 30085

Pre-Filter Replacement Model No.: 30901

HEPA Filter Replacement Model No.: 30936

Hunter Fan Company
Quietflo™ Air Purification System
5 YEAR LIMITED WARRANTY

The Hunter Fan Company makes the following limited warranty to the original residential user or consumer purchaser of the Quietflo™ Air Purification System:

If any part of your Quietflo™ Air Purification System (“Air Purifier”) motor fails during the first five (5) years from the date of installation to you due to a defect in material or workmanship, we will provide a replacement Air Purifier free of charge. Installation is deemed to occur at the date of purchase.

If the Air Purifier cord or front grill fails any time within one (1) year after installation due to a defect in material or workmanship, we will replace or, at our option, repair the unit free of charge at our nearest service centre or at our Service Department in Memphis, Tennessee. You will be responsible for all parts and labour costs after this one-year period.

USE OF A NON-HUNTER FILTER WILL INVALIDATE THIS WARRANTY. IF THE ORIGINAL RESIDENTIAL USER OR CONSUMER PURCHASER CEASES TO OWN THE AIR PURIFIER, THIS WARRANTY AND ANY IMPLIED WARRANTY WHICH THEN REMAINS IN EFFECT, INCLUDING BUT NOT LIMITED TO ANY IMPLIED WARRANTY OF MERCHANTABILITY OR FITNESS FOR A PARTICULAR PURPOSE, ARE VOIDED.

NO WARRANTY, EXPRESSED OR IMPLIED, INCLUDING ANY WARRANTY OF MERCHANTABILITY OR FITNESS FOR A PARTICULAR PURPOSE, IS MADE IN RESPECT TO THE FILTER MATERIAL OR CARBON FILTER.

THIS WARRANTY IS IN LIEU OF ALL OTHER EXPRESS WARRANTIES. THE DURATION OF ANY IMPLIED WARRANTY INCLUDING BUT NOT LIMITED TO ANY IMPLIED WARRANTY OF MERCHANTABILITY OR FITNESS FOR A PARTICULAR PURPOSE, IN RESPECT TO THE MOTOR IS EXPRESSLY LIMITED TO THE PERIOD OF THE EXPRESS WARRANTY SET FORTH ABOVE.

This warranty is voided if the air purifier is not purchased and used in the USA or Canada.

This warranty excludes and does not cover defects, malfunctions or failures of the Air Purifier which were caused by repairs by persons not authorized by us, use of parts or accessories not authorized by us, mishandling, modifications, or damage to the Air Purifier while in your possession, or unreasonable use, including failure to provide reasonable and necessary maintenance. This warranty does not cover Air Purifiers used in commercial applications. There are no express or implied warranties as to commercial purchasers or users.

Continued

To obtain service, contact the nearest Hunter authorized service centre or the Hunter Fan Company Service Department, 2500 Frisco Avenue, Memphis, Tennessee 38114, 901-248-2222. For the name of our nearest authorized Hunter Fan Company Service Centre, write to the Hunter Fan Company at the preceding address. You will be responsible for insurance and freight or other transportation to our factory service center. We will return the Air Purifier freight prepaid. The Air Purifier should be properly packaged to avoid damage in transit since we will not be responsible for any such damage. Proof of purchase is required when requesting warranty service. The purchaser must present sales receipt or other document that establishes proof of purchase.

Hunter Fan Company • 2500 Frisco Avenue
Memphis, Tennessee 38114 • <http://www.hunterfan.com>

