

**EBAC MODEL TRITON
INDUSTRIAL DEHUMIDIFIER
OWNER'S MANUAL**



INTRODUCTION

Designed for a wide range of applications, the Triton dehumidifier is a super high capacity industrial unit which provides fast and efficient drying.

The Triton has a number of special features:

- Super high efficiency rotary compressor
- Temperature-sensitive microprocessor controlled defrost system
- Exterior epoxy powder-coated finish
- Inlet air filter
- Internal condensate pump
- Pump purge system
- Rugged trolley for portability
- Retractable handle mechanism
- Extra long power cord

The fan draws the moist air through the inlet grille on the back of the unit, then through the cold evaporator coil, which cools the air below its dew point. Moisture forms on the evaporator coil and is collected in the condensate tray, which is equipped with a permanent drain. The cooled air then passes through the hot condenser coil where it is reheated using the same energy removed during the cooling phase, plus the additional heat generated by the compressor. The air is, therefore, discharged from the dehumidifier at a slightly higher temperature with a lower absolute humidity than that which entered. Continuous circulation of air through the dehumidifier gradually reduces the relative humidity within the area.

The Triton dehumidifier is a rugged, reliable drying unit designed to operate effectively over a broad range of temperature and humidity conditions.

The unit incorporates a welded and galvanized steel chassis and is finished in an epoxy coating for resilience to damage caused by rough handling.

SPECIFICATIONS

MODEL :	TRITON
HEIGHT :	29"
WIDTH :	20"
DEPTH :	16"
WEIGHT :	75 lbs
AIRFLOW :	282 CFM
POWER SUPPLY :	115V/ 60Hz/ 1 ph
FINISH :	Powder-coated Epoxy
OPERATING RANGE :	41°F – 100°F
REFRIGERANT :	R-22 (16.2 oz)

OPERATION

The following procedures should be followed to test the Triton for correct operation:

1. After unpacking, examine all external features to confirm damage-free shipment. Report all defects and damage at once. Connect the power cable to a grounded 15 Amp electrical outlet.
2. Check dehumidification process as follows:

CAUTION: DO NOT REMOVE COVERS WHEN UNIT IS IN OPERATION.

- A. Place unit on a level surface.
- B. Start up unit by switching to “ON”.
- C. Check that air is being delivered through the front outlet grille and the compressor is running.
- D. Leave the machine running for 60 minutes.
- E. Check to ensure there is sign of water extraction through the condensate drain.
- F. Test the pump surge system operation by holding the momentary pump switch for 5 to 10 seconds. This switch allows you to drain the pump reservoir at the end of a drying job

If, after carrying out the above procedures, the unit does not appear to function properly, refer to the *Trouble Shooting* section, which follows, or contact the Factory Service Center.

CAUTION: Once the unit has been switched off, wait at least five minutes before restarting.

ROUTINE MAINTENANCE

WARNING: ENSURE THAT THE POWER CORD TO THE MACHINE HAS BEEN DISCONNECTED BEFORE CARRYING OUT ROUTINE MAINTENANCE.

To ensure continued full efficiency of the dehumidifier, maintenance procedures should be performed as follows:

1. Replace or clean the inlet air grille as required. Clean the surface of the evaporator and condenser coils by blowing the dirt out from behind the fins with compressed air. Hold the nozzle of the air hose away from the coil to avoid damaging the fins. Alternatively, vacuum clean the coils.

WARNING: DO NOT STEAM CLEAN REFRIGERATION COILS.

2. Check that the fan is firmly secured to the motor shaft and that the fan rotates freely. **The fan motor is sealed for life and therefore does not need oiling.**
3. To check the refrigerant charge, run the unit for 15 minutes and briefly remove the top cover. The evaporator coil should be evenly frost coated across its surface. At temperatures above 70°F, the coil may be covered with droplets of water rather than frost. Partial frosting accompanied by frosting of the thin capillary tubes, indicates loss of refrigerant gas or low charge.
4. Check all wiring connections.

IF ANY OF THE PRECEDING PROBLEMS OCCUR, CONTACT THE EBAC SERVICE CENTER PRIOR TO CONTINUED OPERATION OF THE UNIT TO PREVENT PERMANENT DAMAGE.

REPAIRS

1. Should an electrical component fail, consult the Factory Service Center to obtain the proper replacement part.
2. If refrigerant gas is lost from the machine, it will be necessary to use a refrigeration technician to correct the fault. Contact the Factory Service Center prior to initiating this action.

Any competent refrigeration technician will be able to service the equipment. The following procedure must be used:

- a. The source of the leak must be determined and corrected.
- b. The machine should be thoroughly evacuated before recharging.
- c. The unit must be recharged with refrigerant measured accurately by weight.
- d. For evacuation and recharging of the machine, use the crimped and brazed charging stub attached to the side of the refrigerant compressor.

The charging stub should be crimped and rebrazed after servicing. **NEVER** allow permanent service valves to be fitted to any part of the circuit. Service valves may leak causing further loss of refrigerant gas.

3. The refrigerant compressor fitted to the dehumidifier is a durable unit that should give many years of service. Compressor failure can result from the machine losing its refrigerant gas. The compressor can be replaced by a competent refrigeration technician.

Failure of the compressor can be confirmed by the following procedure:

- a. Establish that power is present at the compressor terminals using a voltmeter.
- b. With the power disconnected, check the continuity of the internal winding by using meter across the compressor terminals. An open circuit indicates that the compressor should be replaced.
- c. Check that the compressor is not grounded by establishing that a circuit does not exist between the compressor terminals and the shell of the compressor.

TROUBLESHOOTING

<u>SYMPTOM</u>	<u>CAUSE</u>	<u>REMEDY</u>
Unit inoperative	1. No power to unit	1. Check the power from power supply panel
Little or no airflow	1. Loose fan on shaft 2. Fan motor burnt out 3. Dirty refrigeration coils 4. Loose electrical wiring 5. Fuse blown or circuit breaker tripped	1. Tighten fan 2. Replace the fan motor 3. See <i>Routine Maintenance</i> Section 4. Check the wiring diagram to find fault and repair 5. Replace the fuse or reset the circuit breaker
Little or no water extraction	1. Insufficient air flow 2. Compressor fault 3. Loss of refrigerant gas	1. Check all of the above 2. Contact the Factory Service Center 3. Contact the Factory Service Center
Little or no defrost when required	1. Faulty timer 2. Faulty by-pass valve	1. Contact the Factory Service Center 2. Contact the Factory Service Center
Unit vibrates excessively	1. Loose compressor 2. Damaged fan	1. Tighten the nuts on the compressor mounts 2. Replace fan
Water flooding inside the machine	1. Drain pipe blocked/frozen 2. Drain pipe too high 3. Crimped or blocked tubing	1. Clear the obstruction 2. Ensure that no section of the drain hose is above the level of the water outlet 3. Straighten, clear, or replace tubing

Ebac Industrial Products
704 Middle Ground Boulevard
Newport News
VA 23606
Telephone (757) 873-6800 FAX (757) 873-3632

TRITON SPARE PARTS LIST

<u>NUMBER</u>	<u>DESCRIPTION</u>	<u>PART NUMBER</u>	<u>QUANTITY</u>
1	Compressor (RGA5456EXA)	3022170	1
2	Compressor Overheat Protector	N/A	1
3	Compressor Capacitor	3030908	1
4	Evaporator/Condenser Coil	2139330	1
5	Grille Filter	2013831	1
6	Filter Dryer	3020901	1
7	Fan Motor	3035788	1
8	By-pass Valve	3020811	1
9	Electronic Timer	1609850	1
10	Axial Fan	3040129	1
11	Rocker Switch	3035914	1
12	Thermistor Assy	3035142	1
13	Solenoid Coil	3030421	1
14	PVC Clear Tube	3014336	1
15	Silicone Tubing	3014368	1
16	Drain Tray	2131107	1
17	Qtr Turn Fastener	3087720	1
18	Qtr Turn Cam	3087721	1
19	Qtr Turn Washer	3087722	1
20	Wheel	3050110	2
21	1" Starlock Washer	3082601	4
22	Condensate Pump	3160129	1
23	Purge Switch	3036779	1
24	Quick Disconnect	3086144	1
25	Snap Hose Clip	3086135	1
26	Hose Clip Snapper	3086136	1
27	Self Locking Pin-1/4x1.5	3087723	1



LIMITED WARRANTY

Our products carry a one-year unconditional warranty against any defects in workmanship or material. This warranty will cover all parts and labor required to repair your Ebac product. This warranty is invalid if the unit has been abused, damaged, whether intentional or accidental, or if any modifications have been made to the unit.

THE FOREGOING WARRANTY IS EXCLUSIVE AND IS ISSUED IN LIEU OF ALL OTHER WARRANTIES (WHETHER WRITTEN, ORAL, OR IMPLIED) INCLUDING THE WARRANTY OF MERCHANTABILITY AND THE WARRANTY OF FITNESS FOR A PARTICULAR PURPOSE. EBAC SYSTEMS, INC. DISCLAIMS ANY LIABILITY FOR CONSEQUENTIAL DAMAGES, LOST PROFITS, OR INCIDENTAL DAMAGES FOR BREACH OF ANY WRITTEN OR IMPLIED WARRANTY WITH RESPECT TO THE FOREGOING DESCRIBED MERCHANDISE.

For Your Records: Model: _____
 S/N: _____
 Date Received: _____

 SAVE THIS SECTION FOR YOUR RECORDS

 CLIP AND RETURN THIS CARD

PLEASE NOTE

To ensure that your Ebac Dehumidifier is accorded the full coverage provided by this warranty, please complete and mail this card at your earliest convenience.

Thank You

WARRANTY REGISTRATION	
MODEL _____ S/N _____	DATE RECEIVED _____
OWNER _____	
ADDRESS _____	
CITY _____ STATE _____	ZIP _____
COMMENTS _____	

Ebac Industrial Products. 704 Middle Ground Boulevard, Newport News, Virginia 23606	

ITEM	DESCRIPTION	PART NUMBER	QTY
1	WHEEL	2139307	2
2	AXLE	2139307	1
3	WATER PUMP	2019902	1
4	COIL SUPPORT	2019902	1
5	DRAIN TRAY	2139325	1
6	REAR GRILLE	2139325	1
7	EVAPORATOR COIL	-----	1
8	CONDENSER COIL	-----	1
9	FIXING PIN	-----	1
10	WIRE BRAID	-----	1
11	L/H STOP BRACKET	2139332	1
12	FRONT GRILLE	2019911	1
13	FAN MOTOR	2019903	1
14	FAN HOUSING	2139304	1
15	TROLLEY HANDLE	-----	1
16	CAPACITOR	-----	1
17	COMPRESSOR	-----	1
18	TROLLEY SUPPORT TRAY	2139308	1
19	RUBBER FOOT	2139306	2
20	TROLLEY LEG	2139306	2
21	FRONT GRILLE PLATE	2019910	1
22	TIP MESH COVER	2139337	1
23	OPERATING LABEL	-----	1
24	MACHINE LABEL	-----	1
25	REAR COVER	2139310	1
26	FILTER BRACKET	2019909	1
27	COVER	2139323	1
28	SUPPORT BRACKET	2139337	1
29	SOLENOID BRACKET	2139339	1
30	R/H STOP BRACKET	2139333	1
31	CONTROL PANEL	2139335	1
32	LABEL BRACKET	2139335	1
33	CAPACITOR STRAP	2019913	1
34	RUBBER PAD	-----	1
35	SILICONE TUBE	-----	1
36	SWAPPER CLIP	-----	1
37	TIMER BOARD	-----	1
38	SOLENOID VALVE	-----	1

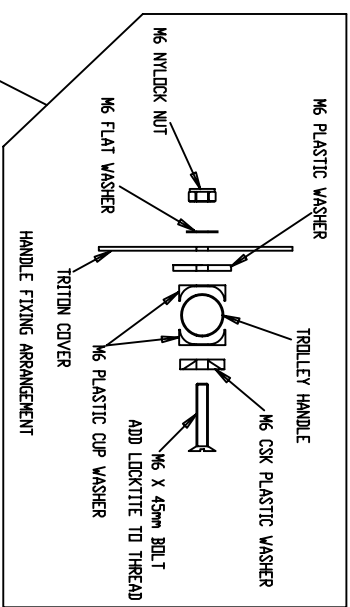
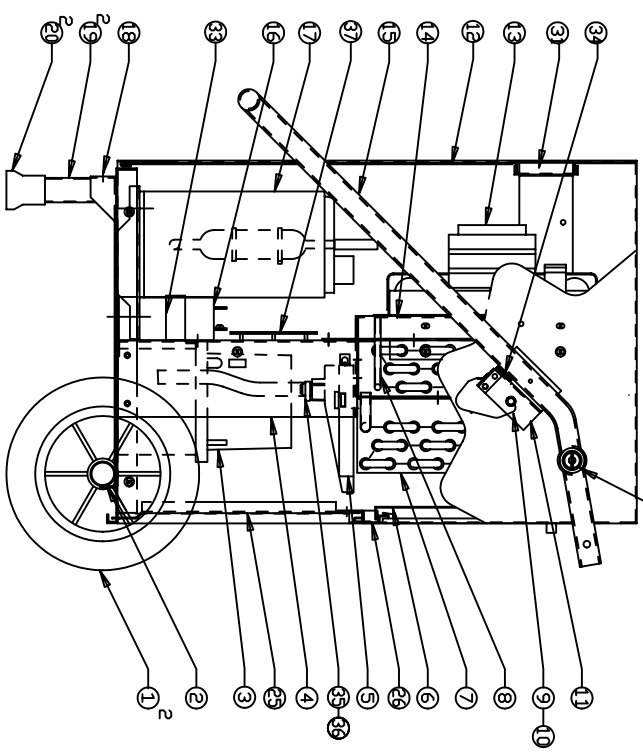
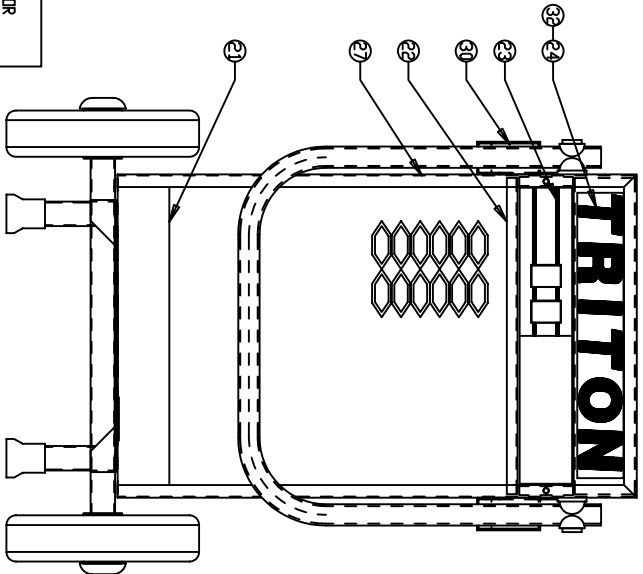
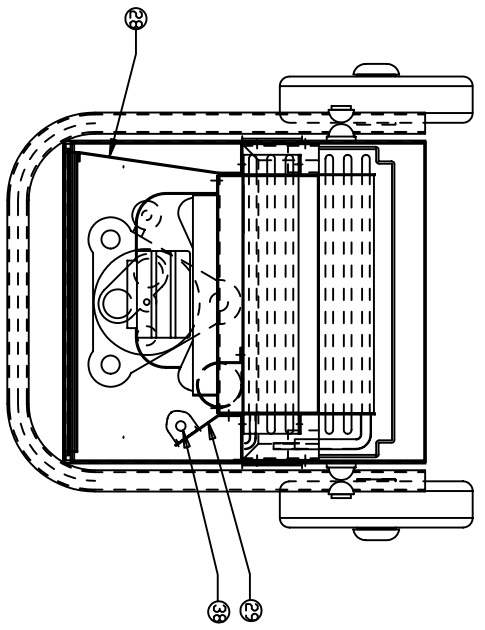

ISSUE	DATE	AMENDMENTS
1	12/05/97	ORIGINAL
2	08/09/97	NEW CONTROL PANEL ADDED - MTD
3	12/01/98	2 HOLES REMOVED FROM CONTROL PANEL - MTD
4	24/03/98	GENERAL ASSEMBLY BROUGHT UP TO DATE - MTD

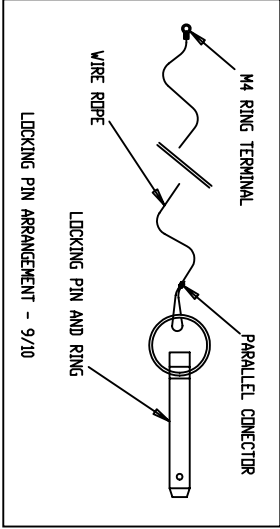

1993
Ebac LIMITED
 BRISTOL ENGLAND

3RD ANGLE PROJECTION
 DO NOT SCALE
 IF IN DOUBT ASK

DIMENSIONS IN mm
 TOLERANCES UNLESS
 OTHERWISE STATED
 0
 0.00
 0.05
 ANGULAR ± 0.5 DEGREE

TITLE: USA 115V 60Hz TRITON DEHUMIDIFIER
 GENERAL ASSEMBLY

MATERIAL: -----
 FINISH: -----

DRAWN: MICHAEL DUNN
 CAD SCALE: 1/6
 DRC: MJD

1139300
 SHEET 1 OF 1

ISSUE	DATE	AMENDMENTS
1	14/04/98	ORIGINAL

--	--	--

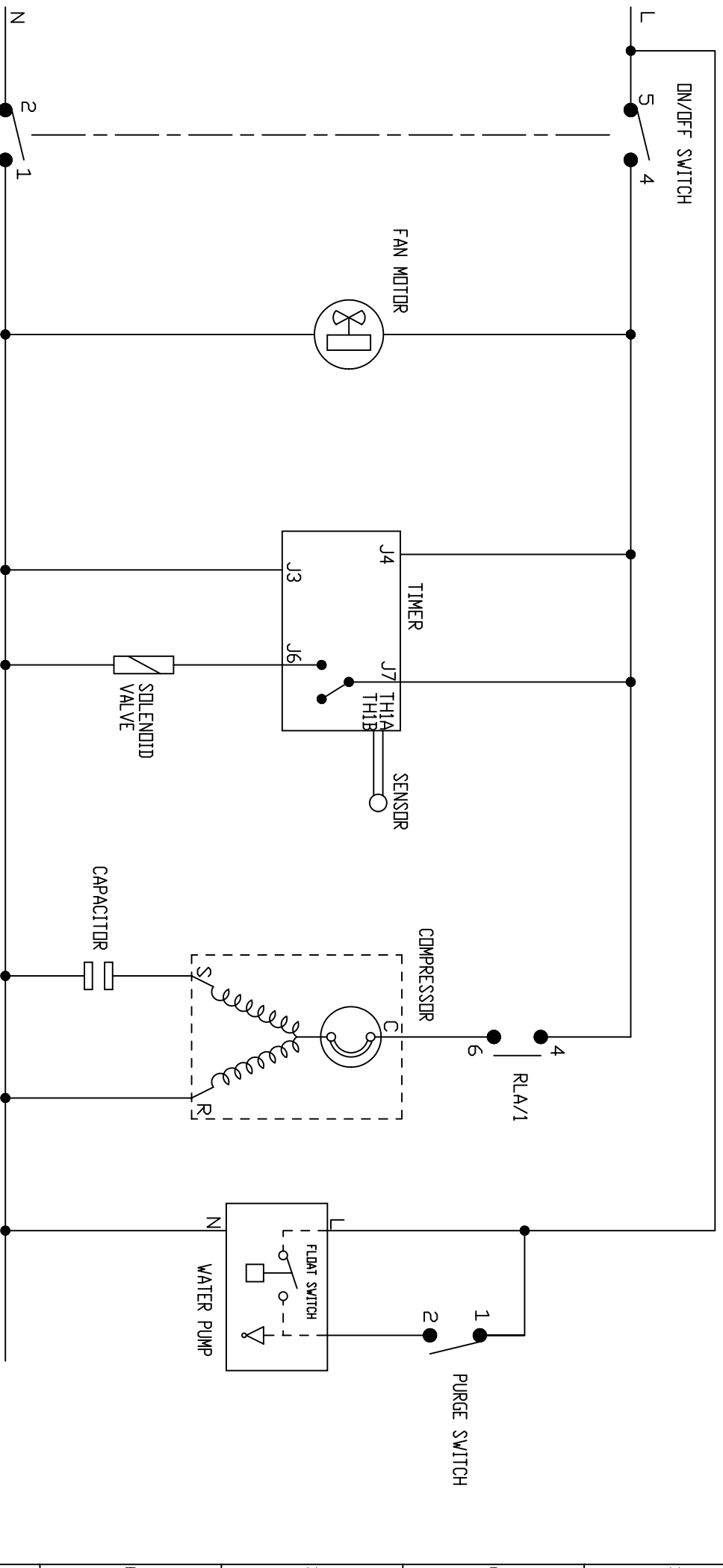

1993 Edgac LIMITED
BRISTOL ENGLAND

TITLE
WIRING SCHEMATIC
TRITON DEHUMIDIFIER

3RD ANGLE PROJECTION
DO NOT SCALE
IF IN DOUBT ASK

DIMENSIONS IN mm
TOLERANCES UNLESS
OTHERWISE STATED

0 ± 1
0.00 ± 0.25
ANGULAR ± 0.5 DEGREE

MATERIAL

DRAWN : JIG LAVERICK

FINISH

CAD SCALE : 1/1

DRAWING : 5020174

SHEET
1 OF 1